



# Husqvarna®



## LC 151, LC 151S, LB 251S, LB 256SP



EN	Operator's manual	2-20
BG	Ръководство за експлоатация	21-41
CS	Návod k použití	42-60
DA	Bruksanvisning	61-79
DE	Bedienungsanweisung	80-100
EL	Οδηγίες χρήσης	101-121
ES	Manual de usuario	122-141
ET	Kasutusjuhend	142-160
FI	Käyttöohje	161-179
FR	Manuel d'utilisation	180-199
HR	Priručnik za korištenje	200-218
HU	Használati utasítás	219-238
IT	Manuale dell'operatore	239-258
JA	取扱説明書	259-278
LT	Operatoriaus vadovas	279-297
LV	Lietošanas pamācība	298-316
NL	Gebbruiksaanwijzing	317-336
NO	Bruksanvisning	337-355
PL	Instrukcja obsługi	356-376
PT	Manual do utilizador	377-396
RO	Instrucțiuni de utilizare	397-416
RU	Руководство по эксплуатации	417-437
SK	Návod na obsluhu	438-457
SL	Navodila za uporabo	458-476
SR	Priručnik za rukovaoca	477-495
SV	Bruksanvisning	496-514
TR	Kullanım kılavuzu	515-533
UK	Посібник користувача	534-553
ZH	操作手册	554-570

# Contents

Introduction.....	2	Engine troubleshooting.....	16
Safety.....	3	Transportation, storage and disposal.....	17
Assembly.....	6	Technical data.....	18
Operation.....	8	EC Declaration of Conformity.....	20
Maintenance.....	11		

## Introduction

### Product description

The product is a pedestrian-controlled rotary lawn mower. For LC 151, LC 151S attach the grass catcher to collect the grass. Attach the side discharge deflector for side discharge of the grass. For LC 151, LC 151S attach a mulch kit to cut the grass into fertilizer.

### Intended use

Use the product to cut grass. Do not use the product for other tasks.

### Product overview

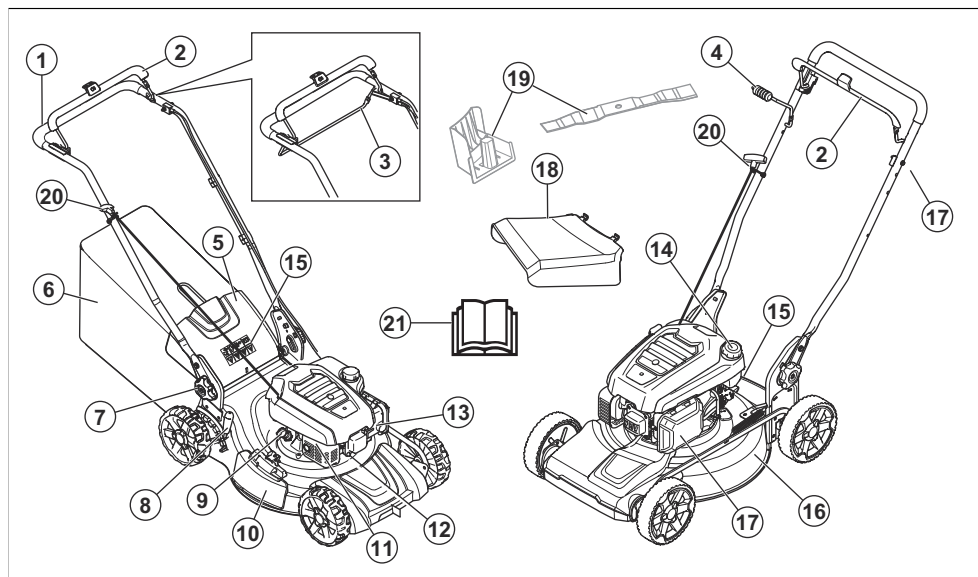

1. Handlebar
2. Engine brake handle
3. Drive bail (LC 151S, LB 256SP)
4. Drive lever (LB 251S)
5. Rear cover (LC 151, LC 151S)
6. Grass catcher (LC 151, LC 151S)
7. Handle height knobs
8. Cutting height lever
9. Oil cap and dipstick
10. Side discharge cover
11. Muffler
12. Spark plug
13. Carburetor
14. Fuel tank cap
15. Symbols
16. Cutting cover
17. Air filter
18. Side deflector
19. Mulch kit (accessory for LC 151, LC 151S)
20. Starter rope handle
21. Operator's manual

## Symbols on the product



**WARNING!** Be careful and use the product correctly. This product can cause serious injury or death to the operator or others.



Please read the operator's manual carefully and make sure that you understand the instructions before use.



Look out for thrown objects and ricochets.



Keep persons and animals at a safe distance from the work area.



Warning: Keep hands and feet away from the rotating blade.



Warning: Keep hands and feet away from rotating parts.



Stop the engine and remove the ignition cable before repairs or maintenance.



This product is in accordance with applicable EC directives.



Noise emission to the environment according to the European Community's Directive. The product's emission is specified in the Technical data chapter and on the label.



Risk of fire.



Do not breathe in exhaust fumes. The exhaust fumes from the engine contain carbon monoxide, an odourless, poisonous and very dangerous gas. Do not start the engine indoors or in closed spaces.



Hot surface.



Fill the engine with oil before you start the product.

---

**Note:** Other symbols/decals on the product refer to certification requirements for some commercial areas.

---

## Product liability

As referred to in the product liability laws, we are not liable for damages that our product causes if:

- the product is incorrectly repaired.
- the product is repaired with parts that are not from the manufacturer or not approved by the manufacturer.
- the product has an accessory that is not from the manufacturer or not approved by the manufacturer.
- the product is not repaired at an approved service center or by an approved authority.

## Euro V Emissions



**WARNING:** Tampering with the engine voids the EU type-approval of this product.

---

## Safety

---

### Safety definitions

Warnings, cautions and notes are used to point out specially important parts of the manual.

---



**WARNING:** Used if there is a risk of injury or death for the operator or bystanders if the instructions in the manual are not obeyed.

---



**CAUTION:** Used if there is a risk of damage to the product, other materials or the adjacent area if the instructions in the manual are not obeyed.

---

**Note:** Used to give more information that is necessary in a given situation.

---

## General safety instructions

---



**WARNING:** Read the warning instructions that follow before you use the product.

---

- This product is dangerous if used incorrectly or if you are not careful. Injury or death can occur if you do not obey the safety instructions.
- This product produces an electromagnetic field during operation. This field may under some circumstances interfere with active or passive medical implants. To reduce the risk of serious or fatal injury we recommend persons with medical implants to consult their physician and the medical implant manufacturer before operating this product.
- Always be careful and use your common sense. If you are not sure how to operate the product in a special situation, stop and speak to your Husqvarna dealer before you continue.
- Keep in mind that the operator will be held responsible for accidents that involve other persons or their property.
- Keep the product clean. Make sure that you can clearly read signs and decals.
- Do not let a person use the product unless you make sure that they read and understand the contents of the operator's manual.
- Do not let a child operate the product.
- Keep children away from the work area. A responsible adult must be there at all times.
- Do not let a person, without knowledge of the instructions, operate the product.
- Always monitor a person, with decreased physical capacity or mental capacity, that uses the product. A responsible adult must be there at all times.
- Do not use the product if you are tired, ill, or under the influence of alcohol, drugs or medicine. This has a negative effect on your vision, alertness, coordination and judgment.
- Do not use the product if it is defective.
- Do not change this product or use it if it is possible that it has been changed by others.
- Do not change the adjustment for the engine speed control.

## Work area safety

---



**WARNING:** Read the warning instructions that follow before you use the product.

---

- Remove objects such as branches, twigs and stones from the work area before you use the product.
- Objects that hit against the cutting equipment can eject and cause damage to persons and objects. Keep bystanders and animals at a safe distance from the product.

- Never use the product in bad weather such as fog, rain, strong winds, intense cold and risk of lightning. To use the product in bad weather or in moist or wet locations is tiring. Bad weather can cause dangerous conditions, such as slippery surfaces.
- Look out for persons, objects and situations that can prevent safe operation of the product.
- Look out for obstacles, such as roots, stones, twigs, pits and ditches. Long grass can hide obstacles.
- To cut grass on slopes can be dangerous. Do not use the product on ground that slopes more than 15°.
- Operate the product across the face of slopes. Do not move up and down.
- Be careful when you go near hidden corners and objects that prevent a clear view.

## Work safety

---



**WARNING:** Read the warning instructions that follow before you use the product.

---

- Use this product to cut grass lawns only. It is not permitted to use it for other tasks.
- Use personal protective equipment. Refer to *Personal protective equipment on page 5*.
- Make sure that you know how to stop the engine quickly in an emergency.
- Never start the engine in a closed space or near flammable material. The exhaust fumes from the engine are hot and can contain sparks which can start a fire.
- Do not operate the product unless the blade and all covers are attached correctly. An incorrectly attached blade can come loose and cause personal injury.
- Make sure that the blade does not hit objects such as stones and roots. This can do damage to the blade and bend the engine shaft. A bent axle causes heavy vibration and a very high risk that the blade becomes loose.
- If the blade hits an object or if vibrations occur, stop the product immediately. Disconnect the ignition cable from the spark plug. Examine the product for damages. Repair damages or let an authorised service agent do the repair.
- Never attach the engine brake handle permanently to the handle when the engine is started.
- Put the product on a stable, flat surface and start it. Make sure that the blade does not hit the ground or other objects.
- Always stay behind the product when you operate it.
- Let all the wheels stay on the ground and keep 2 hands on the handle when you operate the product. Keep your hands and feet away from the rotating blades.
- Do not tilt the product when the engine is started.
- Be careful when you pull the product rearward.

- Never lift up the product when the engine is started. If you must lift the product, first stop the engine and disconnect the ignition cable from the spark plug.
- Do not walk rearward when you operate the product.
- Stop the engine when you move across areas without grass, for example paths made of gravel, stone and asphalt.
- Do not run with the product when the engine is started. Always walk when you operate the product.
- Stop the engine before you change the cutting height. Never make adjustments with the engine started.
- Never let the product stay out of view with the engine started. Stop the engine and make sure that the cutting equipment does not rotate.
- Start the engine and then release the engine brake handle. If the engine does not stop in 3 seconds, let an approved Husqvarna service agent adjust the engine brake.

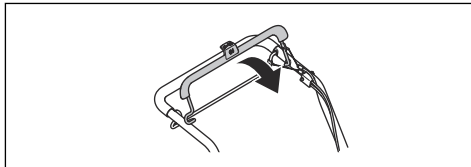

#### To do a check of the rear cover

The rear deflector decreases the risk that objects eject in the direction of the operator.

- Make sure that the rear cover is not damaged.
- Make sure that the springs that close the rear cover are not damaged.
- Replace damaged springs and damaged parts.
- Make sure that the rear cover can move smoothly on the hinges.

## Safety instructions for operation

### Personal protective equipment



**WARNING:** Read the warning instructions that follow before you use the product.

- Personal protective equipment cannot fully prevent injury but it decreases the degree of injury if an accident does occur. Let your dealer help you select the right equipment.
- Use hearing protection if the noise level is higher than 85 dB.
- Use heavy-duty slip-resistant boots or shoes. Do not use open shoes or go with bare feet.
- Use heavy, long pants.
- Use protective gloves when necessary, for example when you attach, examine or clean the cutting equipment.

### Safety devices on the product



**WARNING:** Read the warning instructions that follow before you use the product.

- Do not use a product with defective safety devices.
- Do a check of the safety devices regularly. If the safety devices are defective, speak to your Husqvarna service agent.

#### To do a check of the cutting cover

The cutting cover decreases vibrations in the product and decreases the risk of injury from the blade.

- Examine the cutting cover to make sure that there are no damages such as cracks.

#### To do a check of the engine brake handle

The engine brake handle stops the engine. When the engine brake handle is released, the engine stops.

### Muffler

The muffler keeps the noise levels to a minimum and sends the exhaust fumes away from the operator.

Do not use the product if the muffler is missing or defective. A defective muffler increases the noise level and the risk of fire.



**WARNING:** The muffler becomes very hot during and after use and when the engine operates at idle speed. Be careful near flammable materials and/or fumes to prevent fire.

#### To do a check of the muffler

- Examine the muffler regularly to make sure that it is attached correctly and not damaged.

### Fuel safety



**WARNING:** Read the warning instructions that follow before you use the product.

- Do not start the product if there is fuel or engine oil on the product. Remove the unwanted fuel/oil and let the product dry.
- If you spill fuel on your clothing, change clothing immediately.
- Do not get fuel on your body, it can cause injury. If you get fuel on your body, use soap and water to remove the fuel.
- Do not start the product if the engine has a leak. Examine the engine for leaks regularly.
- Be careful with fuel. Fuel is flammable and the fumes are explosive and can cause injuries or death.

- Do not breathe in the fuel fumes, it can cause injury. Make sure that there is a sufficient airflow.
- Do not smoke near the fuel or the engine.
- Do not put warm objects near the fuel or the engine.
- Do not add the fuel when the engine is on.
- Make sure that the engine is cool before you refuel.
- Before you refuel, open the fuel tank cap slowly and release the pressure carefully.
- Do not add fuel to the engine in an indoor area. Not sufficient airflow can cause injury or death because of asphyxiation or carbon monoxide.
- Tighten the fuel tank cap fully. If the fuel tank cap is not tightened, there is a risk of fire.
- Move the product a minimum of 3 m / 10 ft from the position where you filled the tank before a start.
- Do not fill the fuel tank fully. Heat causes the fuel to expand. Keep a space at the top of the fuel tank.
- The exhaust fumes from the engine contain carbon monoxide, an odourless, poisonous and very dangerous gas. Do not start the engine indoors or in closed spaces.
- Before you do the maintenance on the product, stop the engine and remove the ignition cable from the spark plug.
- Use protective gloves when you do maintenance on the cutting equipment. The blade is very sharp and cuts can easily occur.
- Accessories and changes to the product that are not approved by the manufacturer, can cause serious injury or death. Do not change the product. Always use accessories that are approved by the manufacturer.
- If the maintenance is not done correctly and regularly, the risk of injury and damage to the product increases.
- Only do the maintenance as given in this owner's manual. All other servicing must be done by an approved Husqvarna service agent.
- Let an approved Husqvarna service agent do servicing on the product regularly.
- Replace damaged, worn or broken parts.

## Safety instructions for maintenance



**WARNING:** Read the warning instructions that follow before you use the product.

## Assembly

### Introduction



**WARNING:** Before you assemble the product, you must read and understand the safety chapter.



**WARNING:** Remove the spark plug cable from the spark plug before you assemble the product.

### To assemble the handle

1. Push the screw (A) through the handle (B), the plastic washer (C) and the handle support bracket (D).

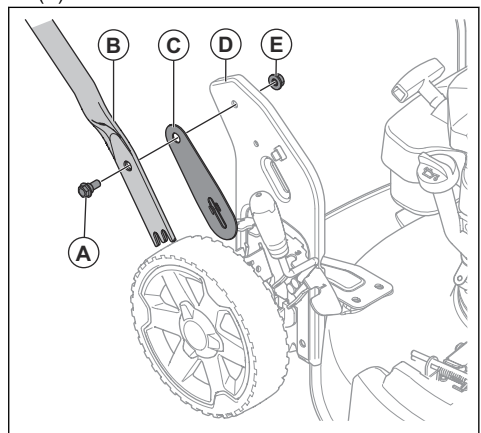

2. Tighten the nut (E) fully.

3. Push the screw (F) through the washer (G) and the handle support bracket.

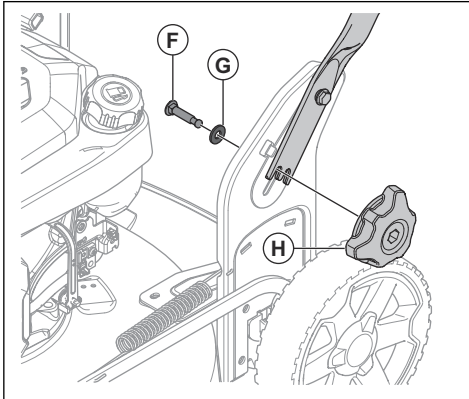

4. Tighten the knob (H) fully.

### To adjust the handle

1. Loosen the lower knobs.
2. Move the knobs to the lower end of the grooves on the left and the right side of the product.

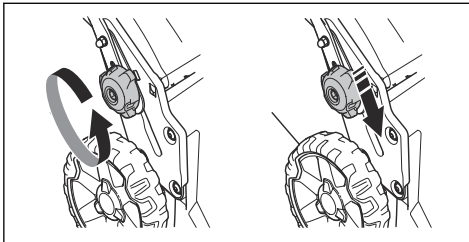

3. Set the handle height in one of the 2 available positions.
4. Move the knobs up in the direction of the handle until they stop and you hear a click.

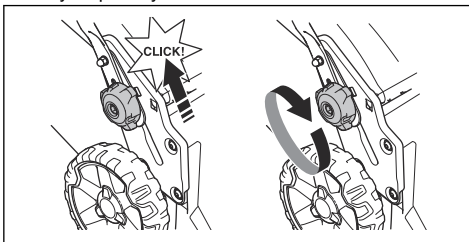

5. Tighten the knobs fully.

### To set the product in transport position

1. Loosen the lower knobs.

2. Move the knobs to the lower end of the grooves on the left and the right side of the product.

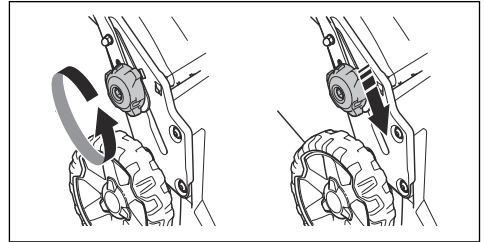

3. Fold the handle forward.

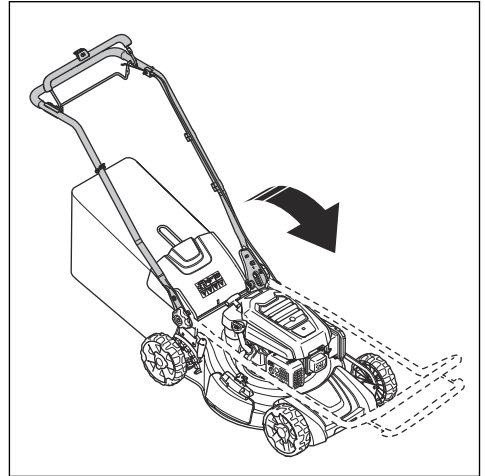

### To set the product in operation position

1. Fold the handle to upright position.

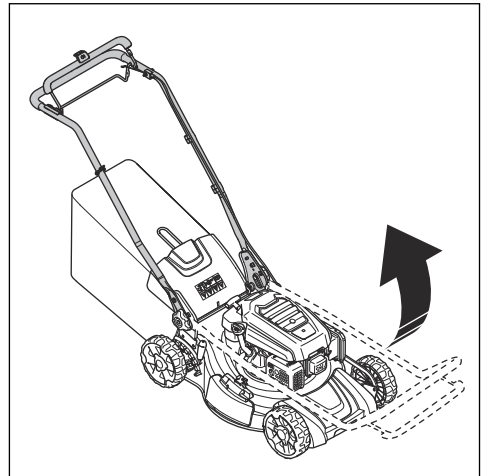

2. Move the knobs up in the direction of the handle until they stop and you hear a click.

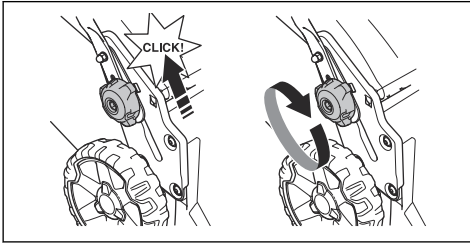

3. Tighten the knobs fully.

## To assemble the grass catcher (LC 151, LC 151S)

1. Attach the grass catcher frame to the grass bag with the rigid part of the bag on the bottom. Keep the handle of the frame out of the top of the bag.

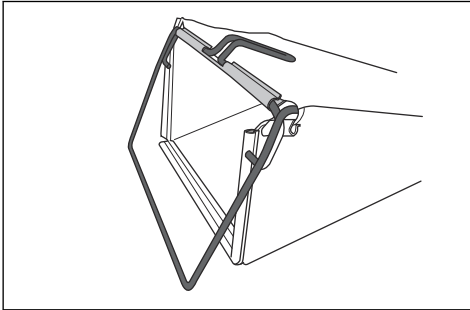

2. Attach the grass bag to the frame with the clips.

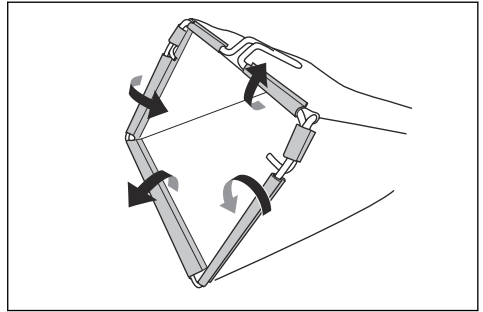

## Operation

### Introduction



**WARNING:** Before you operate the product, you must read and understand the safety chapter.

### Husqvarna Connect

Husqvarna Connect is a free app for your mobile device. The Husqvarna Connect app gives extended functions for your Husqvarna product:

- Extended product information.
- Information about, and help with, product parts and servicing.

### To start to use Husqvarna Connect

1. Download the Husqvarna Connect app on your mobile device.
2. Register in the Husqvarna Connect app.
3. Do the instruction steps in the Husqvarna Connect app to connect and register the product.

### Before you operate the product

1. Read the operator's manual carefully and make sure that you understand the instructions.
2. Examine the cutting equipment to make sure that it is correctly attached and adjusted. See *To examine the cutting equipment on page 13*.
3. Fill the fuel tank. See *To fill fuel on page 8*.
4. Fill the oil tank and do a check of the oil level. See *To do a check of the oil level on page 14*.

### To fill fuel

If available, use low-emission/alkylate gasoline. If low-emission/alkylate gasoline is not available, use good quality unleaded gasoline or leaded gasoline with octane number not less than 90.



**CAUTION:** Do not use gasoline with an octane number less than 90 RON (87 AKI). This can cause damage to the product.



1. Open the fuel tank cap slowly to release the fuel pressure.
2. Fill slowly with a fuel can. If you spill fuel, remove it with a cloth and let remaining fuel dry off.

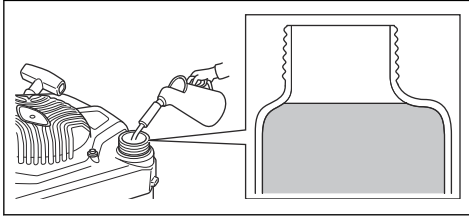

3. Clean the area around the fuel tank cap.
4. Tighten the fuel tank cap fully. If the fuel tank cap is not tightened, there is a risk of fire.
5. Move the product a minimum of 3 m (10 ft) from the position where you filled the tank before a start.

### To set the cutting height

1. Move the cutting height lever rearward to increase the cutting height.
2. Move the cutting height lever forward to decrease the cutting height.

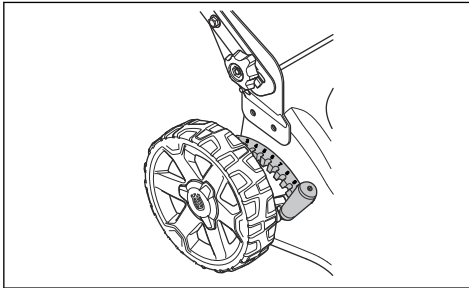

**CAUTION:** Do not set the cutting height too low. The blades can hit the ground if the surface of the lawn is not level.

### To start the product

1. Make sure that the ignition cable is connected to the spark plug.
2. Stay behind the product.
3. Hold the engine brake handle against the handlebar.

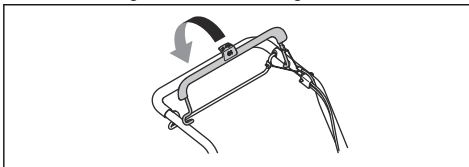

4. Hold the starter rope handle with your right hand.

5. Slowly pull out the starter rope until you feel some resistance.
6. Pull with force to start the engine.



**WARNING:** Do not twist the starter rope around your hand.

### To use the drive on the wheels LC 151S & LB 256SP

- Push the drive bail in the direction of the handlebar.

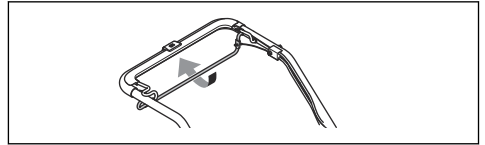

- Release the drive bail to disengage the drive, for example when you go near an obstacle.
- Before you pull the product rearward, disengage the drive and push the product forward approximately 10 cm.

### To use the drive on the wheels (LB 251S)

- Pull the drive lever in the direction of the handlebar.

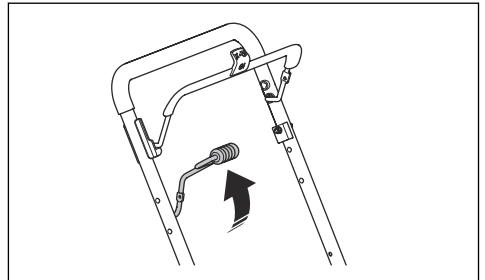

- Push the drive lever away from the handlebar to disengage the drive, for example when you go near an obstacle.

**Note:** The drive lever is automatically disengaged when you release the engine brake handle.

- Before you pull the product rearward, push the drive lever away from the handlebar and push the product forward approximately 10 cm to fully disengage the drive.

### To stop the product

- To stop the drive only, release the drive bail (LC 151S, LB 256SP) or the drive lever (LB 251S).
- To stop the engine, release the engine brake handle.

## To use the product with the grass catcher (LC 151, LC 151S)



**WARNING:** Do not operate the product without a grass catcher installed or without the rear cover closed. Objects can eject and cause injury to the operator.

1. Lift the rear cover and remove the mulch plug if it is installed.

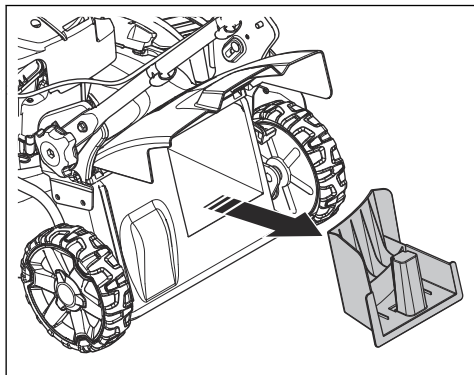

2. Assemble the grass catcher, refer to *To assemble the grass catcher (LC 151, LC 151S) on page 8.*
3. Put the grass catcher on the bracket.
4. Release the rear cover and put it on top of the grass bag frame.

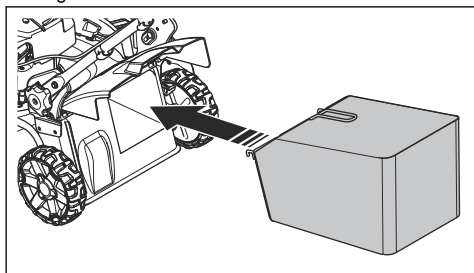

## To change the product to mulch mode (LC 151, LC 151S)

Make sure the engine is off before you change the product to mulch mode.

1. Lift the rear cover and remove the grass catcher, if it is installed.

2. Put the mulch plug into the discharge channel.

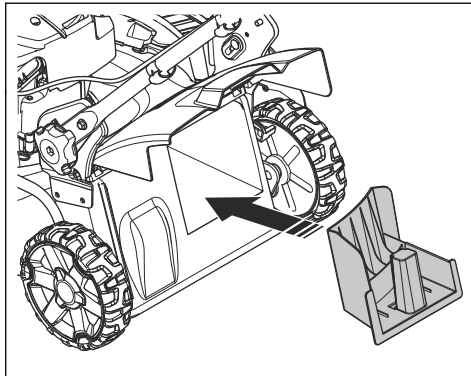

3. Close the rear cover and make sure that it is tightly closed against the mulch plug.

**Note:** To increase the performance of the mulch mode, replace the blade with the mulch blade accessory. Refer to *To replace the blade on page 13*

## To change the product to side discharge mode

1. Lift the rear cover and remove the grass bag, if it is installed.
2. Close the rear cover and make sure that it is tightly closed against the product.
3. Lift the discharge lock.

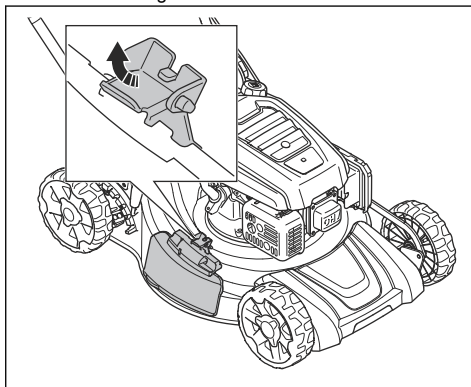

4. Open the side discharge cover and install the side discharge deflector onto the support pins.

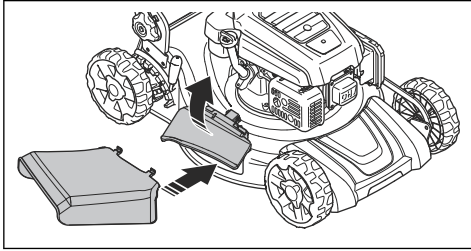

5. Let the side discharge cover close against the side discharge deflector. Make sure that the side discharge deflector is tightly in position before you operate the product.

**Note:** To increase the performance in side discharge mode, install the mulch plug.

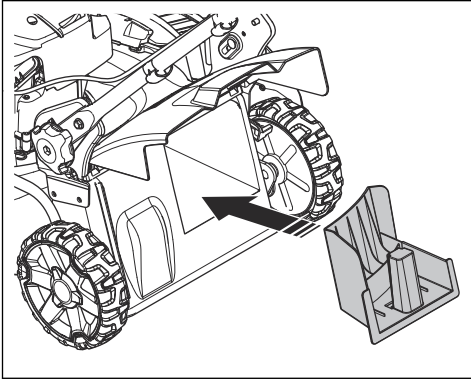

## To empty the grass catcher



**CAUTION:** Lift the grass catcher when you move it to prevent wear.

1. Lift the grass catcher with the frame handle.
2. Use the frame handle and the bag handle when you empty the grass catcher.

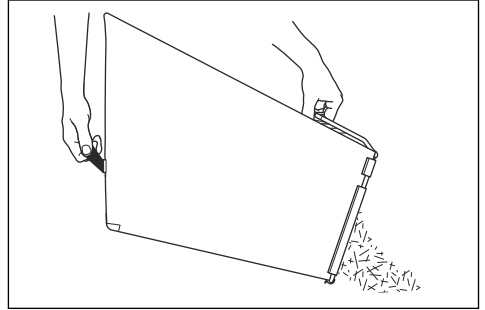

## To get a good result

- Always use a sharp blade. A blunt blade gives an irregular result and the cut surface of the grass becomes yellow. A sharp blade also uses less energy than a blunt blade.
- Do not cut more than  $\frac{1}{3}$  of the length of the grass. Use the highest cutting height when you start to cut the grass. Examine the result and lower the cutting height to an applicable level. If the grass is very long, operate slowly and cut 2 times if it is necessary.
- Cut in different directions each time to prevent stripes in the lawn.
- Lift the rear cover and remove the grass catcher.
- If a mulch plug and a mulch blade are attached, remove them.
- Close the rear cover before you operate the product. When you operate the product, the cut grass discharges below the rear cover.
- Keep the cutting cover clean. Buildup from grass and dirt on the inner side of the cutting cover can decrease the cutting result. Refer to *To clean the inner surface of the cutting cover on page 12.*

## Maintenance

### Introduction



**WARNING:** Before you do maintenance, you must read and understand the safety chapter.

For all servicing and repair work on the product, special training is necessary. We guarantee the availability of professional repairs and servicing. If your dealer is not a service agent, speak to them for information about the nearest service agent.

### Maintenance schedule



**CAUTION:** Make sure that the air filter is up and not against the ground when you tilt the product. Risk of engine damage.

The maintenance intervals are calculated from daily use of the product. The intervals change if the product is not used daily.

For maintenance identified with \* refer to instructions in *Safety devices on the product on page 5.*

Maintenance	Daily	Monthly	Each season
Do a general inspection	X		
Examine the oil level	X		
Replace the oil (the first time after 5 h of use, then after each 50 h of use) <sup>1</sup>			X
Clean the product	X		
Examine the cutting equipment	X		
Examine the cutting cover *	X		
Examine the engine brake handle *	X		
Examine the muffler *		X	
Examine the spark plug. Clean or replace the spark plug if it is necessary			X
Examine the air filter	X		
Clean the air filter <sup>2</sup>		X	
Replace the air filter			X
Examine the fuel system			X
Clean the cooling fins on the cylinder		X	
Examine and adjust the clutch wire (LC 151S, LB 251S, LB 256SP)			X
Clean below the transmission cover (LB 251S)			X

## To do a general inspection

- Make sure that all nuts and screws on the product are tightened correctly.

## To clean the product externally

- Use a brush to remove leaves, grass and dirt.
- Make sure that the air intake on the top of the engine is not blocked.
- Do not use a high pressure washer to clean the product.
- If you use water to clean the product, do not flush water directly on the engine.

## To clean the inner surface of the cutting cover

1. Empty the fuel tank.
2. Tilt the product. Make sure that the spark plug point up.



**CAUTION:** If the product is put with the air filter down, the engine can become damaged.

3. Hose down the inner surface of the cutting cover with water.

## To clean below the transmission cover (LB 251S)

1. Empty the fuel tank.
2. Tilt the product. Make sure that the spark plug point up.



**CAUTION:** If the product is put with the air filter down, the engine can become damaged.

<sup>1</sup> If the product is operated with heavy load or in high ambient temperatures, replace the engine oil each 25 hours.

<sup>2</sup> Clean more often under dusty conditions or when airborne debris is present. Replace air filter, if it is very dirty.

3. Remove the 7 screws.

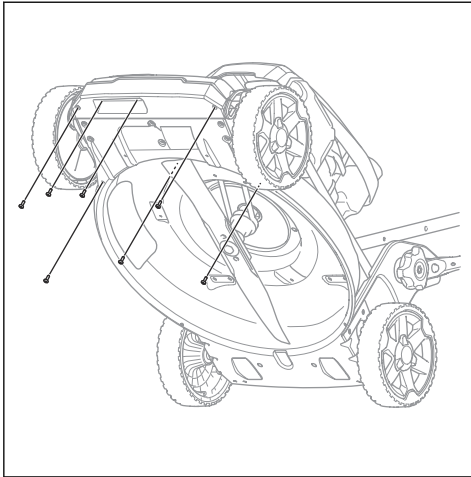

4. Remove the transmission cover.
5. Clean the surface with a brush.



**CAUTION:** Water or contamination below the transmission cover can cause damage to the transmission.

6. Install the transmission cover and the 7 screws.

## To examine the cutting equipment



**WARNING:** To prevent accidental start remove the ignition cable from the spark plug.



**WARNING:** Use protective gloves when you do maintenance on the cutting equipment. The blade is very sharp and cuts can easily occur.

1. Examine the cutting equipment for damage or cracks. Always replace a damaged cutting equipment.
2. Look at the blade to see if it is damaged or blunt.

**Note:** It is necessary to balance the blade after it is sharpened. Let a service center sharpen, replace and balance the blade. If you hit an obstacle that causes the product to stop, replace the damaged blade. Let the service center estimate if the blade can be sharpened or must be replaced.

## To replace the blade

1. Lock the blade with a block of wood.

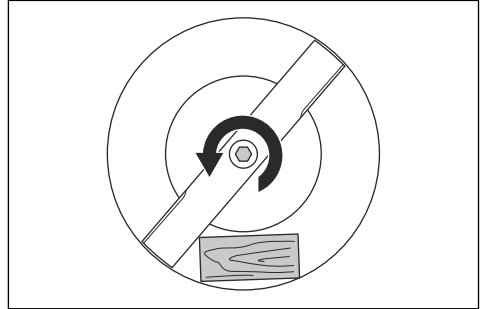

2. Remove the blade bolt and spring washer.
3. Remove the blade.
4. Examine the blade support and blade bolt to see if there are damages.
5. Examine the engine shaft to make sure that it is not bent.
6. When you attach the new blade, point the angled ends of the blade in the direction of the cutting cover.

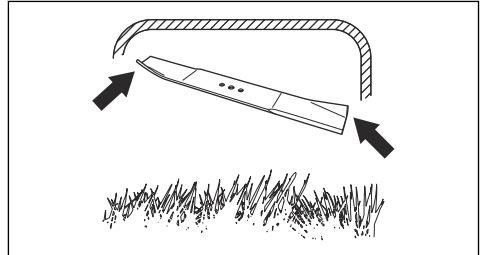

7. Make sure that the blade is aligned with the center of the engine shaft.
8. Lock the blade with a block of wood. Attach the spring washer and tighten the bolt and washer with a torque of 43 – 47 Nm.

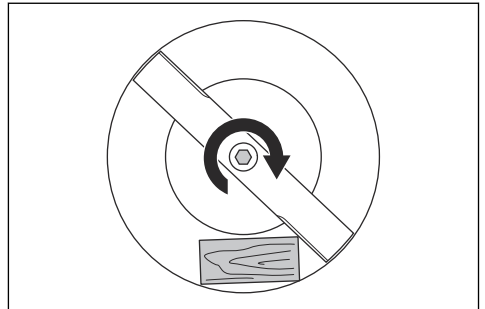

9. Pull the blade around by hand and make sure that it turns freely.



**WARNING:** Use heavy duty gloves. The blade is very sharp and cuts can easily occur.

10. Start the product to do a test of the blade. If the blade is not correctly attached, there is vibration in the product or the cutting result is unsatisfactory.

## To do a check of the oil level



**CAUTION:** A too low oil level can do damage to the engine. Do a check of the oil level before you start the product.

1. Put the product on level ground.
2. Remove the oil tank cap with the attached dipstick.
3. Clean the oil from the dipstick.
4. Put the dipstick fully into the oil tank to give a correct picture of the oil level.
5. Remove the dipstick.
6. Examine the oil level on the dipstick.
7. If the oil level is low, fill with engine oil and do a check of the oil level again.

## To replace the engine oil



**WARNING:** Engine oil is very hot directly after the engine is stopped. Let the engine become cool before you drain the engine oil. If you spill engine oil on your skin, clean with soap and water.

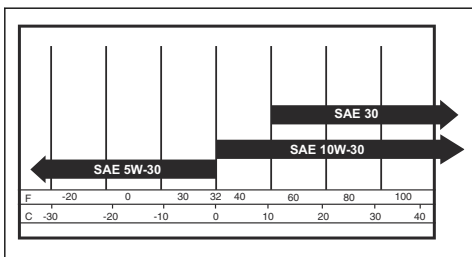

1. Operate the product until the fuel tank is empty.
2. Remove the ignition cable from the spark plug.
3. Remove the oil tank cap.
4. Put a container below the product to collect the engine oil in.
5. Tilt the product to drain the engine oil from the oil tank.
6. Fill with new engine oil of the type recommended in *Technical data on page 18*.
7. Do a check of the oil level. Refer to *To do a check of the oil level on page 14*.

## To examine the spark plug



**CAUTION:** Always use the recommended spark plug type. Incorrect spark plug type can cause damage to the product.

- Examine the spark plug if the engine is low on power, is not easy to start or does not operate correctly at idle speed.
- To decrease the risk of unwanted material on the spark plug electrodes, obey these instructions:
  - a) Make sure that the idle speed is correctly adjusted.
  - b) Make sure that the fuel mixture is correct.
  - c) Make sure that the air filter is clean.
- If the spark plug is dirty, clean it and make sure that the electrode gap is correct, refer to *Technical data on page 18*.

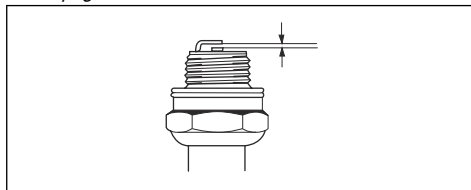

- Replace the spark plug if it is necessary.

## Air filter

A dirty air filter can cause the engine to be damaged or not operate correctly. Do maintenance on the air filter more frequently in dusty conditions. Refer to *Maintenance on page 11* for information about when to replace the air filter.

**Note:** Always replace a damaged air filter.

## To remove and install the air filter



**WARNING:** Use protective gloves.

1. Push the clips on the air filter cover.
2. Carefully remove the air filter cover (A) from the engine.

3. Remove the air filter (B).

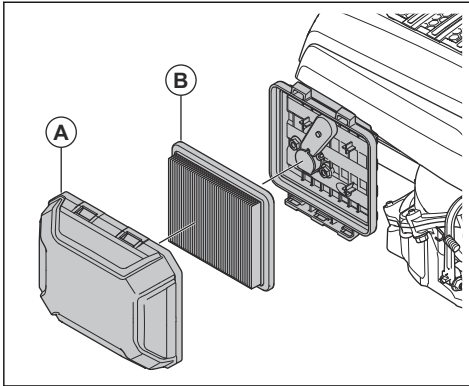

4. Examine the air filter for damages. Replace a damaged air filter.
5. Clean and examine the air filter. Refer to *To clean the air filter on page 15*.
6. Install in the opposite sequence.

### To clean the air filter

A dirty air filter can cause the engine to be damaged or not operate correctly. Do maintenance on the air cleaner more frequently in dusty conditions.

See *Maintenance on page 11* for information about when to replace the air filter.

1. Remove the air filter cover and remove the filter.
2. Clean the filter by hitting it against a flat surface. Do not use solvent with petroleum, kerosene or compressed air to clean the filter.

**Note:** Air filters in operation for a long time cannot be cleaned fully. Replace the air filter at regular intervals. Damaged air filters must always be replaced.

3. When you assemble the air filter, make sure that it fully seals against the filter holder.

### To do a check of the side discharge deflector

The side discharge deflector is attached to the side discharge opening of the product. It decreases the risk of objects to eject in the direction of the mow position of the operator.

1. Make sure that the side discharge deflector is not damaged.
2. Examine the side discharge deflector. Make sure that you do not see defects, such as cracks or broken springs that push the door to close.
3. Replace the side discharge deflector or the springs if they are damaged.

### To examine the fuel system

- Examine the fuel tank cap and the seal for the fuel tank cap to make sure that there are no damages.
- Examine the fuel hose to make sure that there are no leaks. If the fuel hose is damaged, let a service agent replace it.

### To adjust the clutch wire (LC 151S, LB 251S, LB 256SP)

For the situations that follow, it is necessary to decrease the length of the clutch wire:

- The drive of the wheels does not engage when you pull the drive bail or the speed control lever.
- The product moves slowly when the drive of the wheels is engaged.

For the situations that follow, it is necessary to extend the length of clutch wire:

- The product moves when the drive of the wheels is not engaged.
- Adjust the clutch wire.
  - a) To decrease the length of the clutch wire, turn the adjuster screw counterclockwise.
  - b) To extend the length of the clutch wire, turn the adjustment screw clockwise.

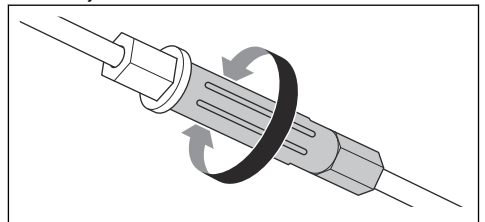

If the product continues to drive unsatisfactory after the adjustment, speak to your servicing dealer

## Engine troubleshooting

Problem	Possible cause	Solution
The engine does not start.	The ignition cable is not connected correctly.	Connect the ignition cable to the spark plug.
	The fuel tank is empty.	Fill the fuel tank with correct fuel type.
	The fuel is old.	Drain the fuel tank and the carburetor. Refuel with new gasoline.
	There is dirt in the carburetor or fuel line.	Clean the carburetor and/or fuel line.
	The spark plug is defective.	Adjust the electrode gap, clean or replace the spark plug.
	There is fuel on the spark plug.	Clean the spark plug.
The engine does not stop.	The stop mechanism is defective.	Disconnect the ignition cable from the spark plug. Let an approved service agent repair the product.
The engine does not operate smoothly.	The ignition cable is not connected correctly.	Connect the ignition cable to the spark plug.
	There is dirt in the fuel line or the fuel has expired.	Clean the fuel line. Fill the fuel tank with new fuel of the correct type.
	There is blockage in the fuel tank cap.	Clean the fuel tank cap.
	There is water or dirt in the fuel system.	Drain the fuel tank. Fill the fuel tank with new fuel of the correct type.
	The air filter is dirty.	Clean the air filter.
	The carburetor must be adjusted.	Let a servicing dealer adjust the carburetor.
The engine becomes too hot.	The engine oil level is too low.	Fill engine oil.
	The air flow is not sufficient.	Clean the air filter and the air filter housing.
	The carburetor must be adjusted.	Let a servicing dealer adjust the carburetor.
There is misfire in the engine when it operates at high speed.	The electrode gap in the spark plug is too small.	Adjust the electrode gap.
Unusual noises from the engine during normal load.	Incorrect type of gasoline.	Drain the fuel tank and the carburetor. Refuel with new gasoline. Refer to <i>To fill fuel on page 8</i> . If the problem continues speak to your local service dealer.
The engine does not operate smoothly at idle speed.	The spark plug is dirty, defective or the electrode gap is too wide.	Adjust the electrode gap or replace the spark plug.
	The carburetor must be adjusted.	Adjust the carburetor.
	The air filter is dirty.	Clean the air filter.



---

## Transportation, storage and disposal

---

### Transportation and storage

- For storage and transportation of the product and fuel, make sure that there are no leaks or fumes. Sparks or open flames, for example from electrical devices or boilers, can start a fire.
- Always use approved containers for storage and transportation of fuel.
- Empty the fuel tank before you put the product in storage for a long period of time. Discard the fuel at an applicable disposal location
- Safely attach the product during transportation to prevent damage and accidents.
- Keep the product in a locked area to prevent access for children or persons that are not approved.
- Keep the product in a dry and frost free area.

### Disposal

- Obey the local recycling requirements and applicable regulations.
- Discard all chemicals, such as engine oil or fuel, at a service center or at an applicable disposal location.
- When the product is no longer in use, send it to a Husqvarna dealer or discard it at a recycling location.

## Technical data

### Technical data

	LC 151	LC 151S	LB 251S	LB 256SP
<b>Engine</b>				
Brand	Husqvarna	Husqvarna	Husqvarna	Husqvarna
Engine type	Single cylinder, 4-Stroke, Forced Air Cooling, OHV	Single cylinder, 4-Stroke, Forced Air Cooling, OHV	Single cylinder, 4-Stroke, Forced Air Cooling, OHV	Single cylinder, 4-Stroke, Forced Air Cooling, OHV
Displacement, cm <sup>3</sup>	166	166	166	166
Speed, rpm	2800	2800	2800	2800
Nominal engine output, kW <sup>3</sup>	2.7	2.7	2.7	2.7
<b>Ignition system</b>				
Spark plug	Husqvarna HQT-7	Husqvarna HQT-7	Husqvarna HQT-7	Husqvarna HQT-7
Electrode gap, mm	0.7–0.8	0.7–0.8	0.7–0.8	0.7–0.8
<b>Fuel and lubrication system</b>				
Engine lubrication type	Splash	Splash	Splash	Splash
Fuel tank capacity, litre	1.0	1.0	1.0	1.0
Oil tank capacity, litre	0.5	0.5	0.5	0.5
Engine oil <sup>4</sup>	Husqvarna SAE 30	Husqvarna SAE 30	Husqvarna SAE 30	HusqvarnaSAE 30
<b>Weight</b>				
With empty tanks, kg	31.1	32.6	32.0	33.1
<b>Noise emissions<sup>5</sup></b>				
Sound power level, measured, dB(A)	97	97	95	98
Sound power level, guaranteed, L <sub>WA</sub> dB(A)	98	98	96	98
<b>Sound levels<sup>6</sup></b>				

<sup>3</sup> The power rating of the engine indicated is the average net output (at specified rpm) of a typical production engine for the engine model measured to SAE standard J1349/ISO1585. Mass production engines may differ from this value. Actual power output for the engine installed on the final product will depend on the operating speed, environmental conditions and other values.

<sup>4</sup> If SAE-30 oil is used at temperatures lower than +5 °C, there is a risk that it does not lubricate the engine sufficiently. This can cause engine damage. Refer to *To replace the engine oil on page 14* for the correct oil for low temperatures.

<sup>5</sup> Noise emissions in the environment measured as sound power (L<sub>WA</sub>) in conformity with EC directive 2000/14/EC.

<sup>6</sup> Reported data for noise pressure level has a typical statistical dispersion (standard deviation) of 1.2 dB (A).

	<b>LC 151</b>	<b>LC 151S</b>	<b>LB 251S</b>	<b>LB 256SP</b>
Sound pressure level at operators ear, dB(A)	85	85	82	88
<b>Vibration levels<sup>7</sup></b>				
Vibrations handlebar, m/s <sup>2</sup>	8.5	8.5	4.7	7.5
<b>Cutting equipment</b>				
Cutting height, mm	25–75	25–75	25–75	25–75
Cutting width, mm	510	510	510	560
Cutting system	Collection / Bio-Clip® / Side discharge	Collection / Bio-Clip® / Side discharge	BioClip® / Side discharge	BioClip® / Side discharge
Blade - standard	Collection 598562601	Collection 598562601	Mulch 597683901	Mulch 598563601
Blade - Accessory	Mulch 597683901	Mulch 597683901	–	–
Grass catcher capacity, liter	65	65	–	–
<b>Drive</b>				
Self walk speed, km/h	–	3.6	4.0	3.6

<sup>7</sup> Reported data for vibration level has a typical statistical dispersion (standard deviation) of 0.2 m/s<sup>2</sup>.

---

# EC Declaration of Conformity

---

## EC Declaration of Conformity

**Husqvarna AB**, SE-561 82 Huskvarna, Sweden, tel: +46-36-146500, declares that the **lawn mower Husqvarna LC 151, LC 151S, LB 251S, LB 256SP** from the year 2020 and onwards, complies with the requirements of the COUNCIL'S DIRECTIVE:

- of June 8, 2011 on the "restriction of use of certain hazardous substances" **2011/65/EU**
- of May 17, 2006 "relating to machinery" **2006/42/EC**
- of February 26, 2014 "relating to electromagnetic compatibility" **2014/30/EU**
- of May 8, 2000 "relating to the noise emissions in the environment" **2000/14/EC**

Information relating to noise emissions, see Technical data.

The following standards have been applied:

**EN ISO 5395-1:2013, EN ISO 5395-1:2013/A1, EN ISO 5395-2:2013, EN ISO 5395-2:2013/A1:2016, EN ISO 5395-2:2013/A2:2017, EN ISO 14982:2009**

If not otherwise stated, the above listed standards are the latest published versions.

Notified body: **0404, RISE SMP Svensk Maskinprovning AB, Box 7035, SE-750 07 Uppsala, Sweden** has performed conformity assessment according to Annex VI of directive 2000/14/EC.

Huskvarna, 2021-11-30



Claes Losdal, Development Manager/Garden Products  
(Authorized representative for Husqvarna AB and responsible for technical documentation)